

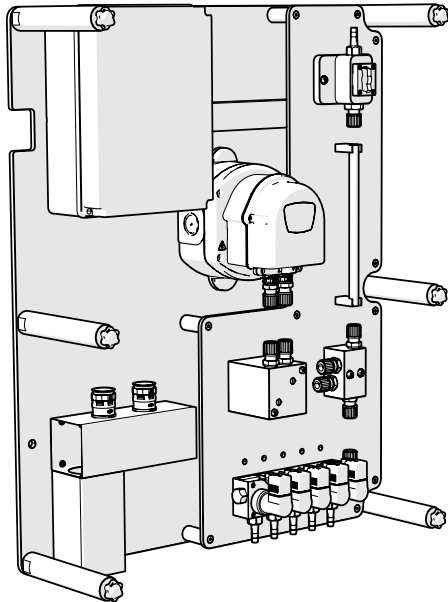

EXPANSION CHANNEL (ELECTRICAL) MULTIPLEX ACCESSORY



Description

Introducing our innovative Industrial Laundry Expansion Channel, designed to integrate seamlessly with our **Multiplex 1 Pro** or **Multiplex 2 Pro** units.

Electric solenoid valves: The expansion channel is equipped with state-of-the-art electric solenoid valves, providing reliable and accurate control over water flow. This ensures optimum performance and efficient resource utilization in your laundry operations.

Configuration: Different options with 1, 2 or 4 products provide flexible solutions tailored the different requirements of each laundry.

Technical Specifications

		Value
CONFIGURATION	Number of products	1
		2
		4
ELECTRIC PARAMETERS	Voltage	24VDC
	Power	120W
WATER	Pressure in dynamic range	Min 22 PSI - Max 44 PSI
		Regulator recommended
	Flow range	Min 68 fl oz/min (Approx)
		Max 338 fl oz/min (Approx)
	Inlet connection	3/8" barbed connector
	Maximum temperature	< 86° F
	Required hardness	8 - 8.5 gpg (grains per gallon)
Booster tank	Not included. Supplied on request. Recommended.	

Technical Specifications

		Value
PANELS	Material	PVC
	Number	1 pump per channel. Main channel: electric diaphragm
PUMPS	Flow rate (with water)	51 fl oz per minute
	Body	PVDF
	Membranes	PTFE
	Check valves	PVDF/FFKM
	Voltage	24VDC
PRODUCT/WATER VALVES	Body	PP
	Closure piston	PTFE
	O-rings	PVDF/FFKM
FLOW METERS	Standard measuring principle	Paddles + Hall effect sensor
	Signal	24 VDC PNP
	Body	PP
	Palettes	PVDF
	O-rings	FKM
	Alternative	*Oval gear not included. Supplied on request. Recommender with chemicals 180cP or higher.
CALIBRATION	Mode	Via distributor
	Measuring vase	Not included * recommended

Details

Part Code	Description	Width	Height	Depth
A500CHP01B1	MULTIPLEX - ELECTRIC EXPANSION CHANNEL C1 1,5L	23"	31"	9"
A500CHP02B1	MULTIPLEX - ELECTRIC EXPANSION CHANNEL C2 1,5L	23"	31"	9"
A500CHP04B1	MULTIPLEX - ELECTRIC EXPANSION CHANNEL C4 1,5L	23"	31"	9"

T (+1) 913-956-4909 E sales@brightwell-inc.com W brightwell-inc.com/

Brightwell Dispensers Inc. 9858 Britton Street, Lenexa, KS, 66219

All information in this data sheet is correct at the time of printing and is subject to change without notice.

Revision 1.2
02/2025
B1079US

Diagram

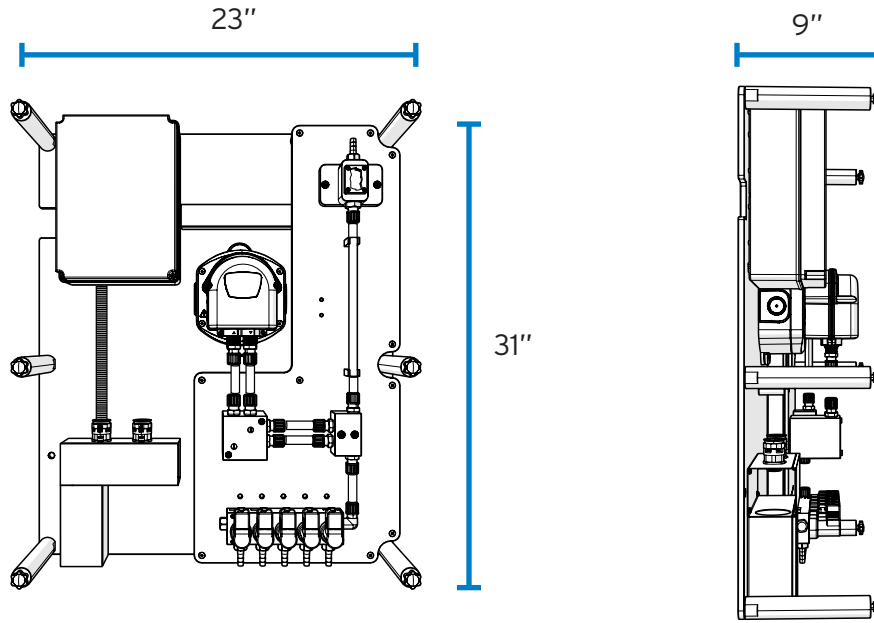

Dimensions

Width	23"
Height	31"
Depth	9"

Weight

Unit	42lbs (approx)
------	----------------

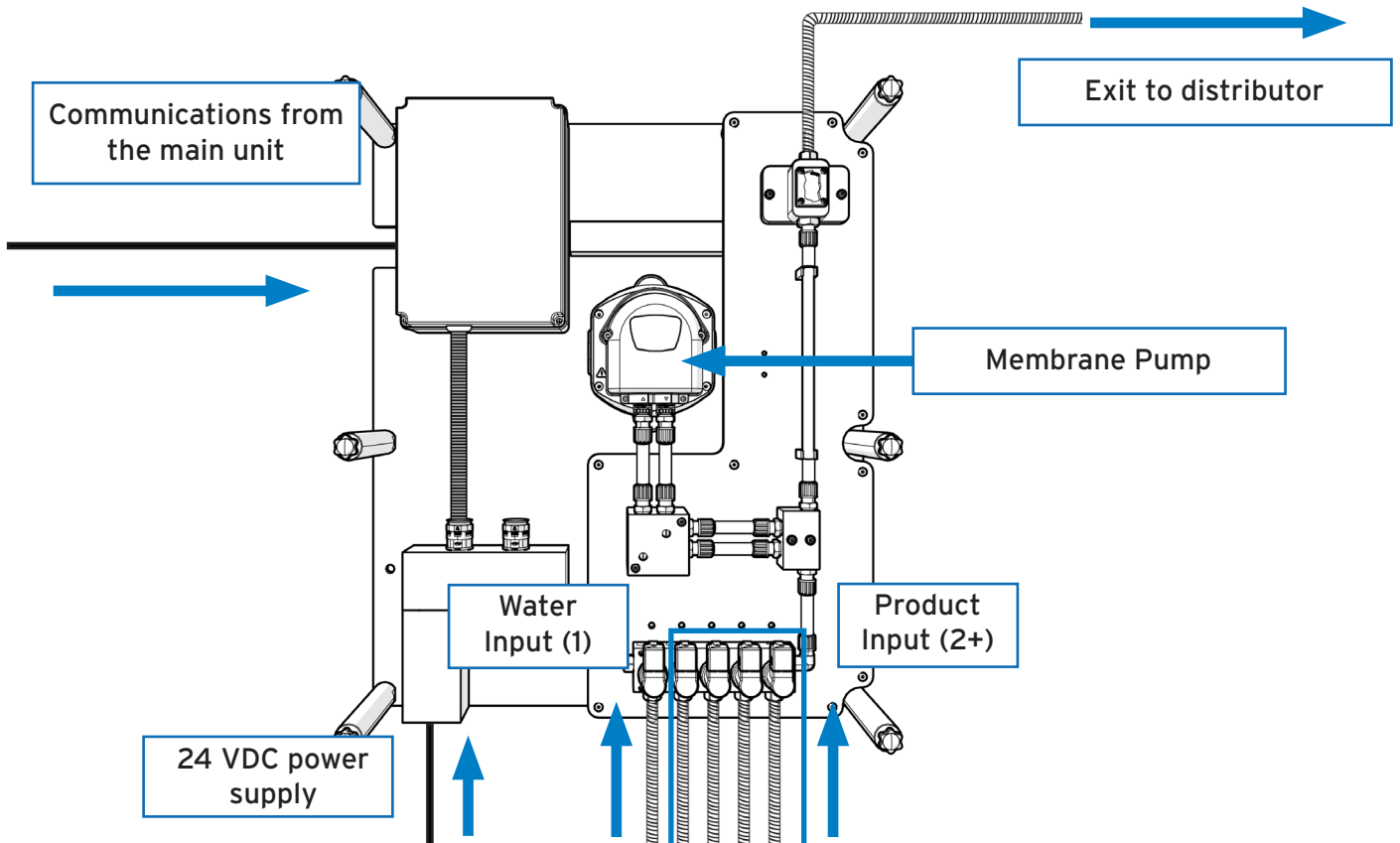

T (+1) 913-956-4909 E sales@brightwell-inc.com W brightwell-inc.com/

Brightwell Dispensers Inc. 9858 Britton Street, Lenexa, KS, 66219

All information in this data sheet is correct at the time of printing and is subject to change without notice.